

Rahmen St9.1

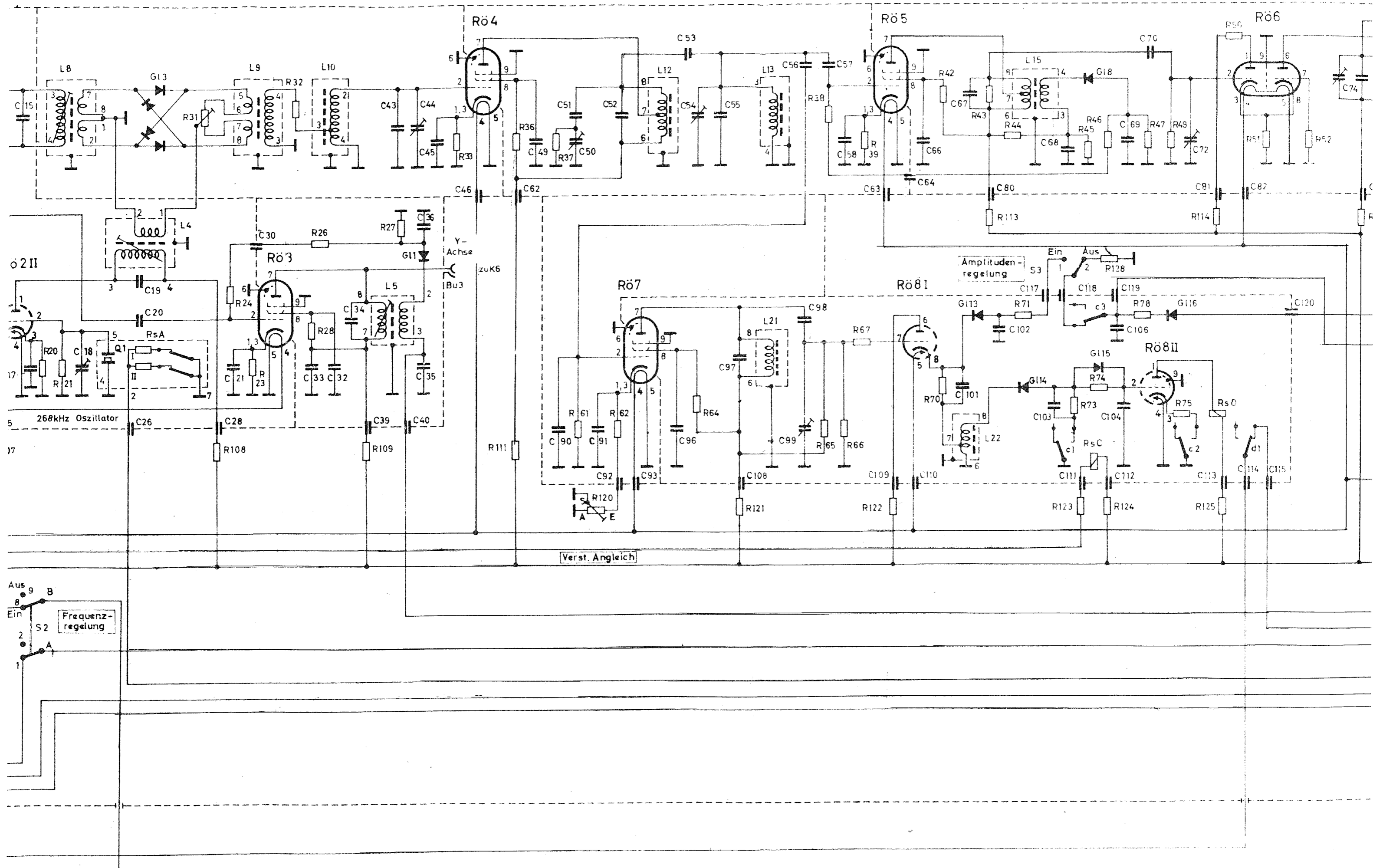

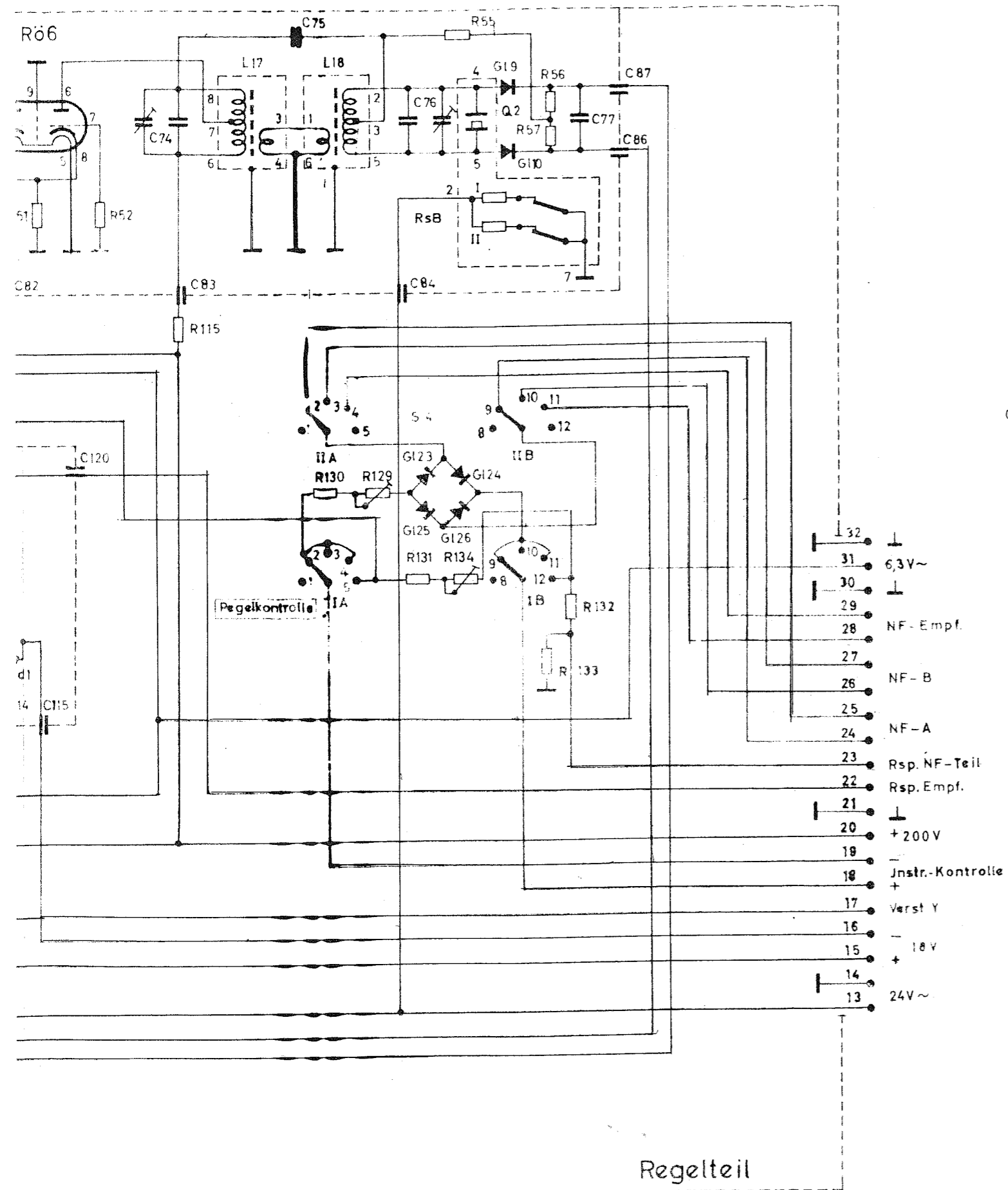

Regelteil

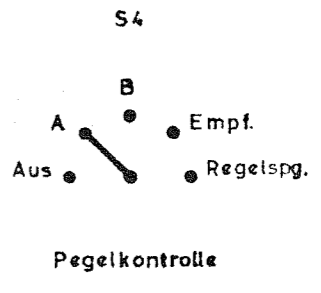
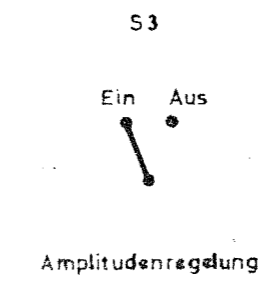
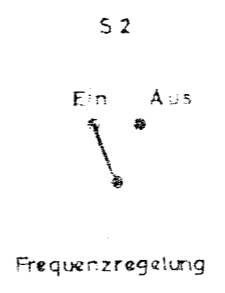
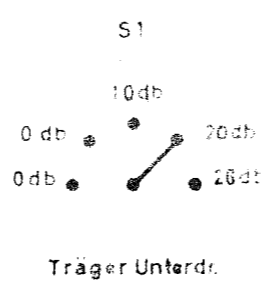
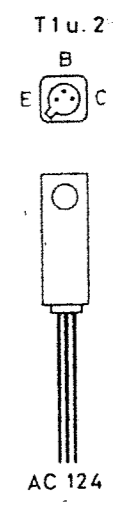
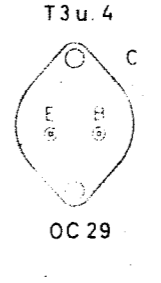
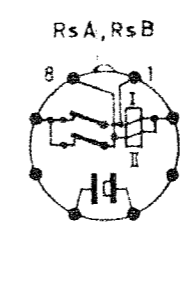
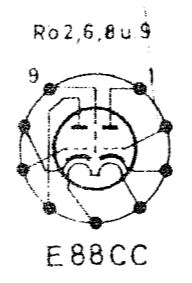
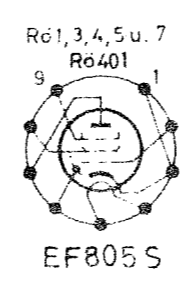

- 32 ⊥
- 31 6,3V~
- 30 ⊥
- 29 NF- Empf.
- 28 NF- B
- 27 NF- A
- 26 NF- A
- 25 NF- A
- 24 NF- A
- 23 Rsp. NF-Teil
- 22 Rsp. Empf.
- 21 ⊥
- 20 + 200V
- 19 -
- 18 Instr.-Kontrolle
- 17 +
- 16 Verst Y
- 15 - 18V
- 14 +
- 13 24V~

TDv 5820/073-13
Abschnitt 2

Stromlauf besteht aus 4 Blatt
hierzu Schaltteilliste Blatt 1, 16

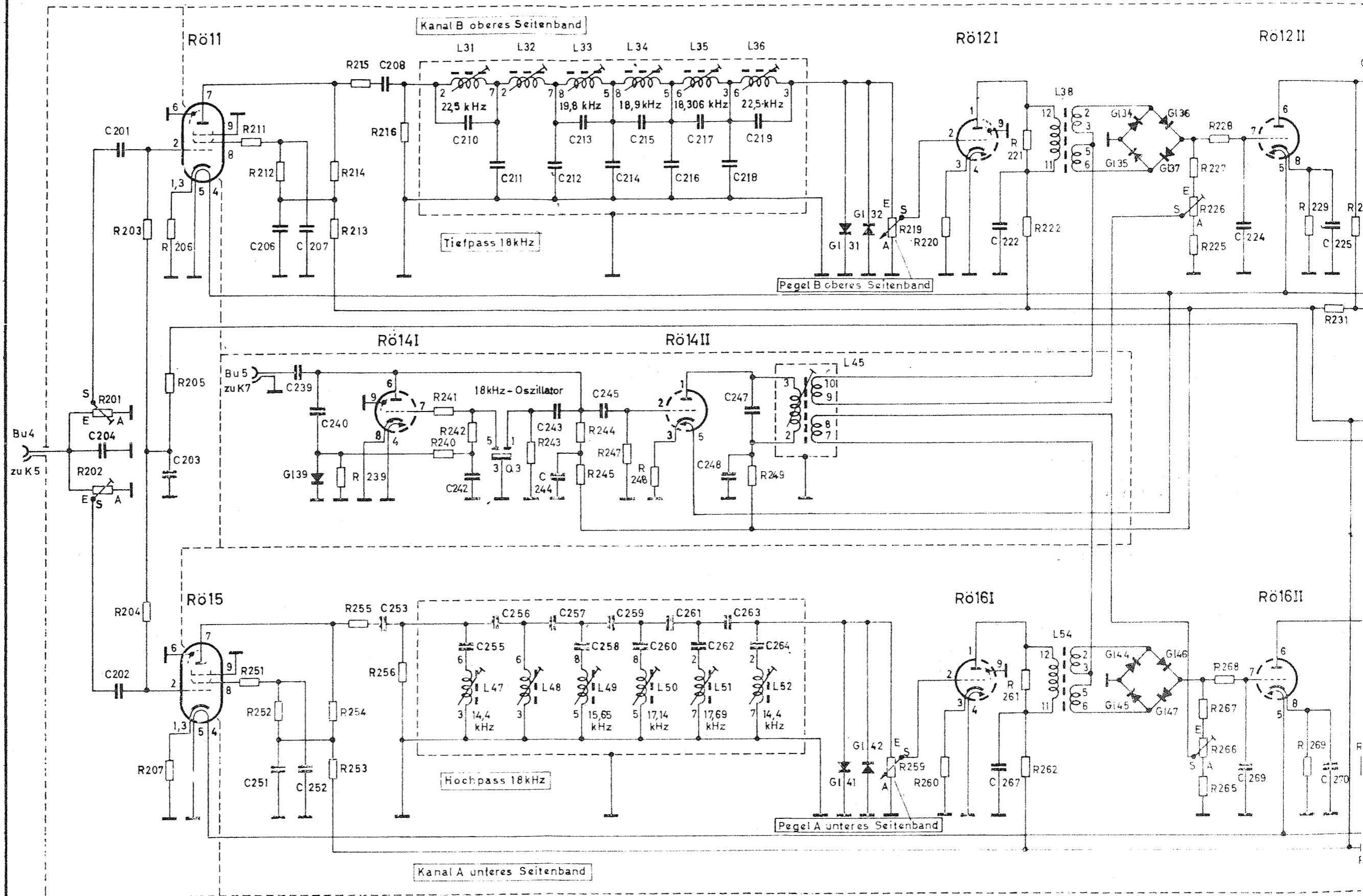

EF805S

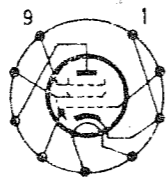

RÖ11 u. 15

E88CC

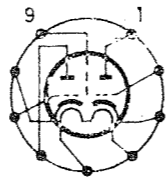

RÖ12, 13, 14 u. 16

QS15

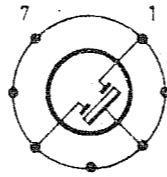

Q 3

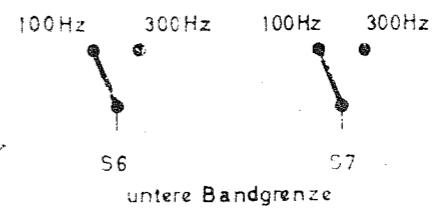

Abhör Ausgang

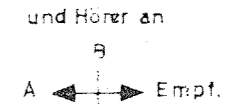

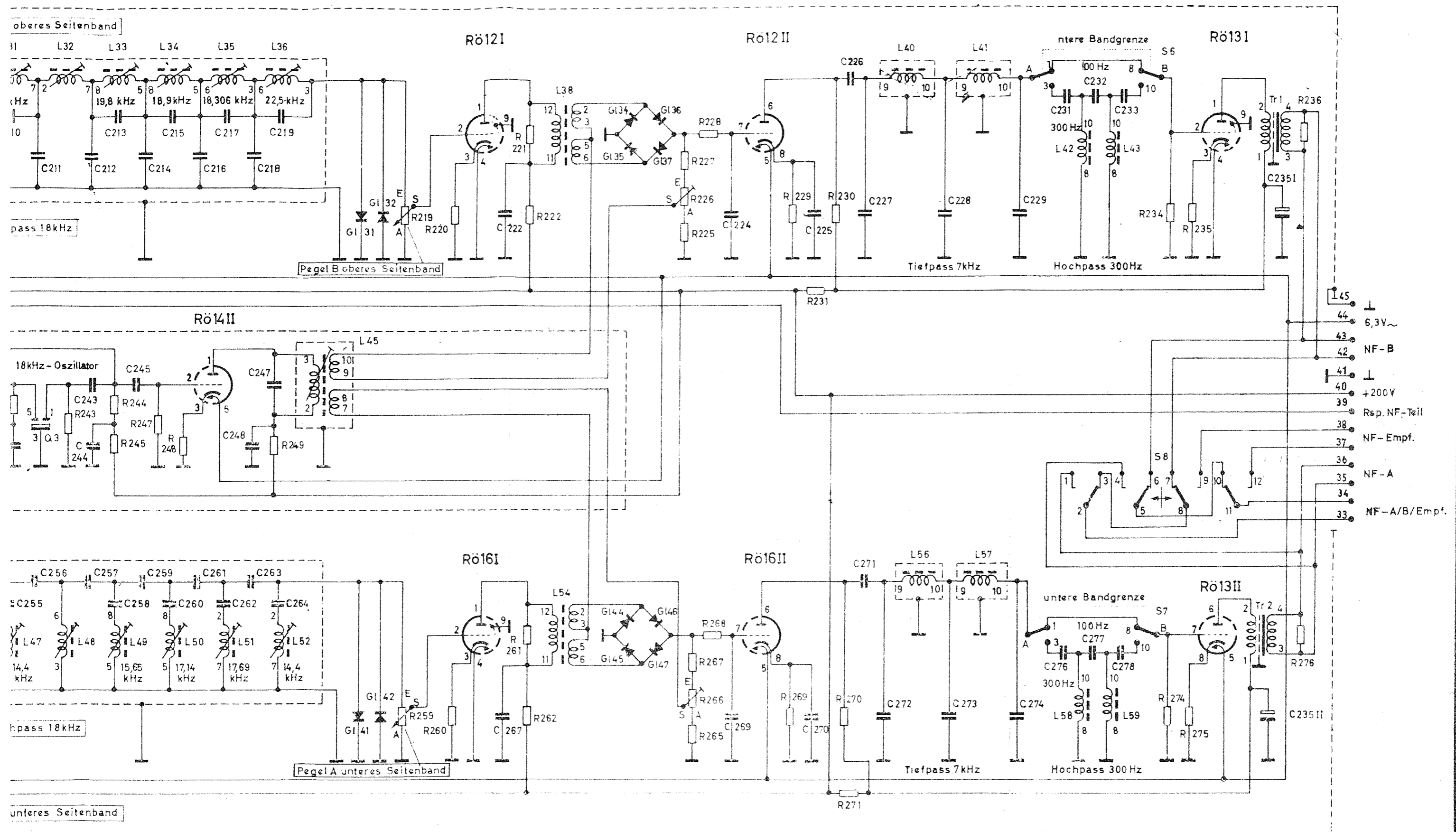

- 45 ⊥
- 44 6,3V~
- 43
- 42 NF-B
- 41 ⊥
- 40 +200V
- 39 Resp. NF-Teil
- 38 NF-Empf.
- 37
- 36 NF-A
- 35
- 34 NF-A/B/Empf.
- 33

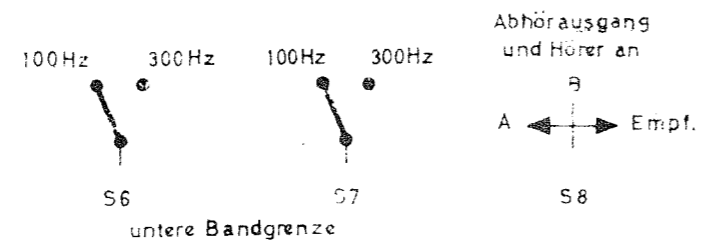
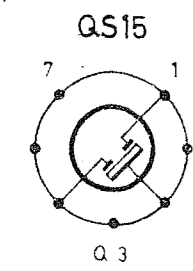

TDv 5820/073-13
Abschnitt 2

NF-Teil, hierzu Schalteilliste NZ10/2 Sa. Bl. 17...25

Einseitenband-Demodulator

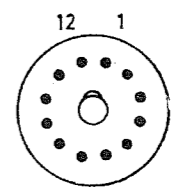
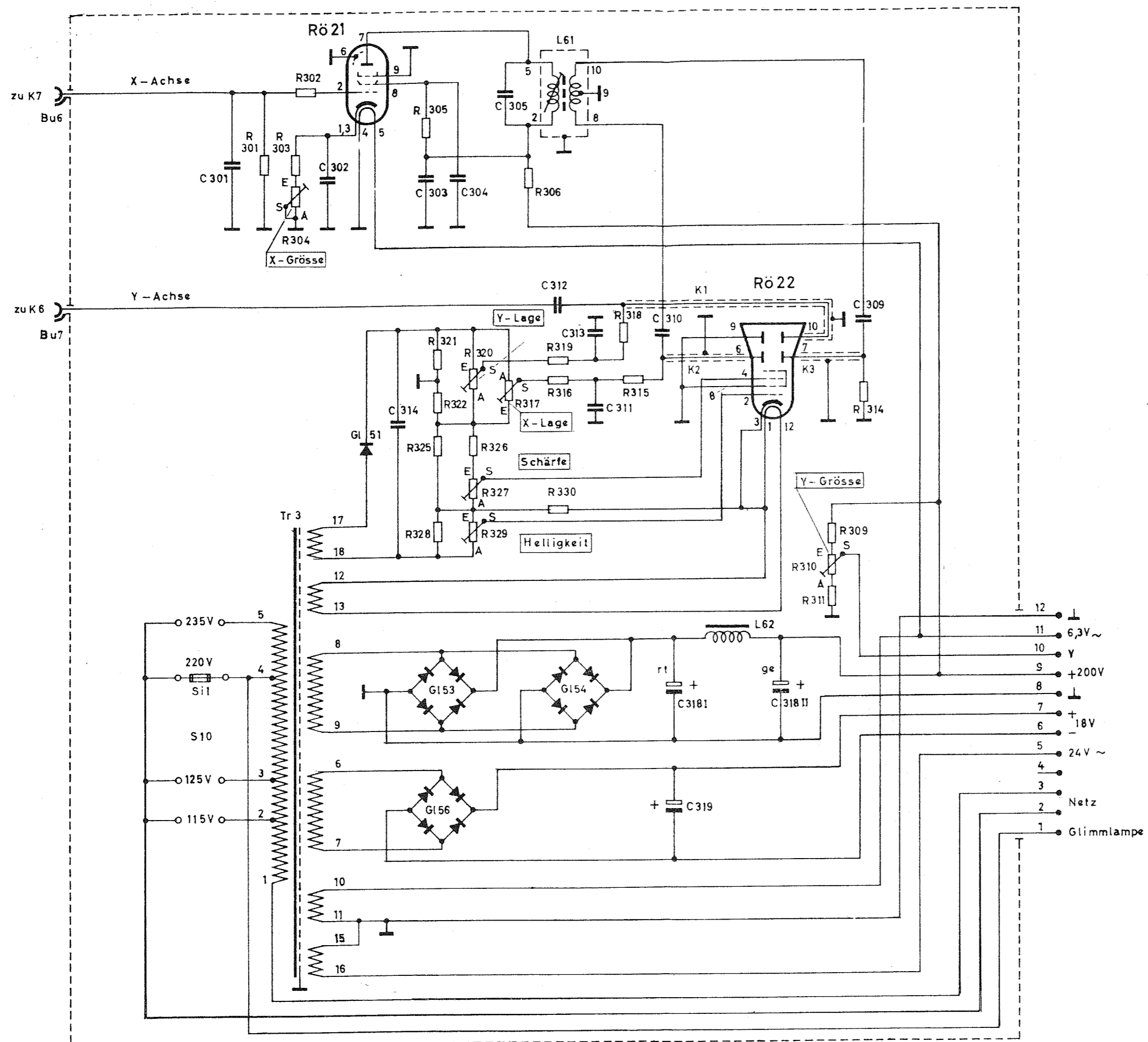

DG7-31
Rö 22

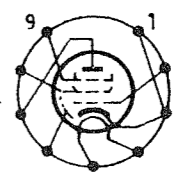

EF805 S
Rö 21

- 12
- 11 6,3V~
- 10 V
- 9 +200V
- 8
- 7
- 6 +18V
- 5 -18V
- 4
- 3
- 2 Netz
- 1 Glimmlampe

TDv 5820/073-13
Abschnitt 2

Netzteil; hierzu Schalteilliste NZ10/2Sa Bl.26...28

Stromlauf zu
Einseitenband-Demodulator

Zeichn. Nr.
NZ10/2 S
121